

PORTA-PAK *Specials*



ONE-WAY SCREW REMOVER/ INSTALLER P/N 19527











ONE-WAY SCREW REMOVER / INSTALLER

- Patented one way screw remover and installer
- Makes installation of one-way screws fast and easy
- Allen set screw for adjustment of bit depth (hex keys included)
- Use with corded or cordless screwguns and drills



QTY	WIRE CONNECTOR	PART #	QTY	WIRE CONNECTOR	PART #
1	#6 On Way Screw Remover/Installer	81325	1	#8 On Way Screw Remover/Installer	81326
1	#10 On Way Screw Remover/Installer	81327	1	#12 On Way Screw Remover/Installer	81328
1	#14 On Way Screw Remover/Installer	81329	5	Hex Keys	

HD LOBULAR MAGNETIC NUTSETTERS P/N 19533

  <p>P/N 82991 - 3/16" x 2-9/16"</p>	  <p>P/N 82992 - 1/4" x 2-9/16"</p>
  <p>P/N 82993 - 5/16" x 2-9/16"</p>	  <p>P/N 82994 - 3/8" x 2-9/16"</p>
  <p>P/N 82995 - 7/16" x 2-9/16"</p>	<p>EXPANSION</p>

CHROMATE INDUSTRIAL CORP. • 1-800-BUY-BOLT • Fax: 631-567-2418 • www.chromate.com

MISCELLANEOUS SCREWS

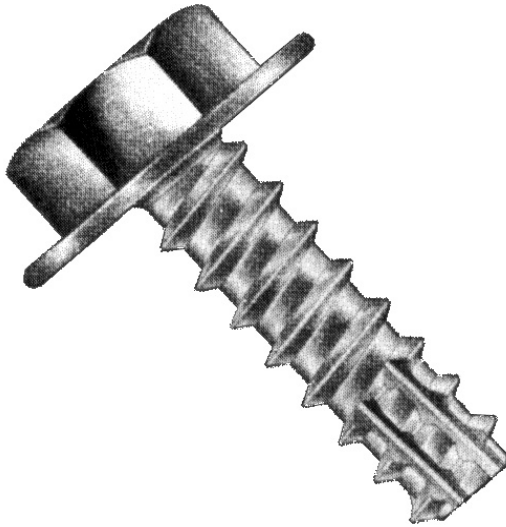

- High Performance Bi-Cut Screws For Plastic, Fiberglass, Wood and Masonite
- Drywall Screws
- Security Screws
- Thread Cutting Type F Point Screws
- Tamperproof Shoulder Screws
- Nutsetters, Bits and Bit Holders

CHROMATE SPECIALTY SCREWS HELP SOLVE ALL YOUR SPECIAL APPLICATION PROBLEMS. Designed and engineered for those unique situations where standard fasteners are inadequate. Look to Chromate for all your fastener needs.



CHROMATE INDUSTRIAL CORP.

EXCEPTIONAL PRODUCTS, SERVICE AND INNOVATIVE SOLUTIONS

DRIVER BITS

NUTSETTERS AND BITS FOR DRILLS AND SCREW GUNS

Made from shock resistant tool steel and heat treated for maximum strength and hardness. For longest life, always use the correct size bit for the screw you are driving.

QUICK CHANGE CHUCK ADAPTER

- Convert your speed control drill to A 1/4" "quick change" power screwgun
- Allows "quick change" 1/4" Hex power bits
- 3/8" Shank



DESCRIPTION	PART
1/4" QC Chuck Adapter	A 83066

HD LOBULAR MAGNETIC NUTSETTERS - 1/4" HEX SHANK

- S2 Tool Steel material, hardened with a proprietary coating
- Lobular hex bit design minimizes the "rounding out" of the fastener head
- Lobular design provides more clearance on the corners
- Made in the USA



SIZE	LENGTH	SCREW	PART
3/16"	2-9/16"	2-4	A 82991
1/4"	2-9/16"	6-8	A 82992
5/16"	2-9/16"	10-12	A 82993
3/8"	2-9/16"	14-1/4	A 82994
7/16"	2-9/16"	14	A 82995
1/4"	6"	6-8	A 82980*
5/16"	6"	10-12	A 82981*
3/8"	6"	14-1/4	A 82982*
3/16"	1-5/8"	2-4	A 82983*
1/4"	1-5/8"	6-8	A 82984*
5/16"	1-5/8"	10-12	A 82985*
3/8"	1-3/4"	6-8	A 82986*
7/16"	1-3/4"	14	A 82987*
1/4"	4"	6-8	A 82988*
5/16"	4"	10-12	A 82989*
3/8"	4"	14-1/4	A 82990*

* Items with an asterisk are non-stocking (10 day delivery ARO).

PHILLIPS PIN HEAD INSERT BIT



SIZE	SCREW	PART
#2	#5 - 10	B 83120
#3	#12 - 16	B 83121

TORX® INSERT BIT - 1/4" HEX



SIZE	SCREW	1" LENGTH
T6	#2	B 83050
T7	#3	C 83051
T8	#4	C 83052
T9	#5	C 83053
T10	#6	C 83054
T15	#6 - #8	C 83055
T20	#8	C 83056
T25	#10 - #12	C 83057
T27	#12 - 1/4	C 83058
T30	#14 - 1/4	C 83059
T40	5/16 - 3/8	C 83064

TORX® SECURITY INSERT BIT



• 1/4 HEX

SIZE	SCREW	1" LENGTH
T8	#4	B 83099
T9	#5 - #6	B 83091
T10	#6 - #8	B 83092
T15	#8 - #10	B 83093
T20	#8	B 83094
T25	#10 - #12	B 83095
T27	#12 - 1/4	B 83096
T30	#14 - 1/4	B 83097
T40	5/16 - 3/8	B 83098

NUTSETTER 1/4" HEX SHANK x 6" LONG



SIZE	SCREW	MAGNETIC
1/4"	6-8	A 82996
5/16"	10-12	A 82997
3/8"	14-1/4	A 82998
7/16"	14	A 82999

NUTSETTER 1/4" HEX SHANK x 2-9/16" LONG



SIZE	SCREW	MAGNETIC	NON-MAG.
1/4"	6-8	A 83005	A 83015
5/16"	10-12	A 83006	A 83016
3/8"	14-1/4	A 83007	A 83017
7/16"	14	A 83008	A -

TRI-WING INSERT BIT



SIZE	SCREW	PART
W3	#6	B 83122
W4	#8	B 83123
W5	#10	B 83124

LOCK-N-LOAD® QUICK CHANGE EXTENSION

IRWIN



- Carbon steel construction sleeve And body for durability and life
- Lock-n-load® system for one-handed release
- Patented jaw design holds bits securely on 6-flatted shanks, as well as ball detent bits
- 1/4" Quick change range now holds insert bits; magnetic for holding

SHANK SIZE	LENGTH (OAL)	PART
1/4"	2"	A 83132
1/4"	6"	A 83133
1/4"	12"	A 83134
3/8"	2"	A 83135
3/8"	5-1/2"	A 83136
3/8"	12"	A 83137
7/16"	5-1/2"	A 83138
7/16"	12"	A 83139
7/16"	18"	A 83140

NUTSETTER 1/4" HEX SHANK x 1-7/8" LONG



SIZE	SCREW	MAGNETIC	NON-MAG.
1/4"	6-8	A 83000	A 83010
5/16"	10-12	A 83001	A 83011
3/8"	1/4	A 83002	A 83012

DRIVER BITS

NUTSETTERS AND BITS FOR DRILLS AND SCREW GUNS

PHILLIPS POWER BITS

- 1/4 HEX



SIZE	SCREW	1-15/16"	2-3/4"	6"
1	2-4	C 83025	C 83030	C 83041
2	5-10	C 83026	C 83031	C 83042
3	12-16	C 83027	C 83032	C 83043

PHILLIPS INSERT BITS

- 1/4 HEX



SIZE	SCREW	1" LENGTH
1	2-4	C 83021
2	5-10	C 83022
3	12-16	C 83023

WING NUT DRIVER 1/4"

- NEW PATENTED DESIGN WHICH TIGHTENS WING NUTS



DESCRIPTION	PART
1/4" Wing Nut Driver	A 83090

SLOTTED POWER BIT W/FINDER



SIZE	SCREW	3-3/4" LGTH
5F-6R	#5 - #6	C 83060
6F-8R	#6 - #8	C 83061
10F-12R	#10 - #12	C 83062

SLOTTED POWER BITS

- 1/4 HEX



BLADE SIZE	SCREW	2-3/4" LGTH	6" LGTH
1/4	6F-8R	A 83046	A 83047
5/16	10F-12R	A 83048	A 83049

MAGNETIC BIT HOLDER - 1/4" HEX

- MADE OF INDUSTRIAL QUALITY STAINLESS STEEL



SIZE	2-1/4" LENGTH	3" LENGTH	6" LENGTH
1/4	A 83018	A 83020	C 83019

SLOTTED INSERT BITS - 1/4" HEX



SIZE	SCREW	1" LENGTH	SIZE	SCREW	1" LENGTH
3F-4R	#4	C 83070	8F-10R	#8	C 83073
4F-5R	#5	C 83071	10F-12R	#10	C 83074
5F-8R	#6	C 83072	12F-14R	#12	C 83075

DRYWALL SCREW SETTER

- SETS DRYWALL SCREW INTO DRYWALL
- EASY TO USE IN DRILLS OR SCREW GUNS



DESCRIPTION	PART
Drywall Screw Setter	C 83065

SQUARE INSERT BITS - 1/4" HEX



1" LONG



2" LONG

SIZE	SCREW	1" LGTH	2" LGTH	3" LGTH
#1	6	D 7065	D 7069	D 7072
#2	8-10	D 7066	D 7070	D 7073
#3	12-14	D 7067	D 7071	D 7074

SPANNER SECURITY INSERT BIT - 1/4" HEX



SIZE	SCREW	1" LGTH	SIZE	SCREW	1" LGTH
#4 x 1	#4	B 83080	#10 x 1	#10	B 83083
#6 x 1	#6	B 83081	#12 x 1	#12	B 83084
#8 x 1	#8	B 83082	1/4 x 1	1/4	B 83085

REPLACEMENT BITS FOR 10-IN-1 SCREWDRIVER

- P/N 83125 #1 Phillips x 3/16" Slotted Bit
- P/N 83126 #2 Phillips x 1/4" Slotted Bit
- P/N 83127 #1 x #2 Square Recessed Bit
- P/N 83128 T15 x T20 TORX® Bit



PHILLIPS



SLOTTED



TORX®



ROBERTS/
SQUARE

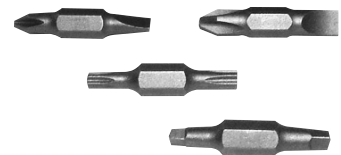

DRIVER BITS

NUTSETTERS AND BITS FOR DRILLS AND SCREW GUNS

DOUBLE ENDED INSERT BITS PHILLIPS/SLOTTED - 1/4" HEX



SIZE	SCREW	LENGTH	PART
1 Phil / 6 Slotted	2-4 and 6-8	1-1/2	c 83100
2 Phil / 4 Slotted	5-10 and 4-6	1-1/2	c 83101
3 Phil / 10 Slotted	12-16 and 10-12	1-1/2	c 83102

DOUBLE ENDED INSERT BITS SQUARE/SQUARE - 1/4" HEX



SIZE	SCREW	LENGTH	PART
1 Square / 2 Square	6 and 8-10	1-1/2	c 83103

DOUBLE ENDED INSERT BITS - 5/16" HEX



SIZE	SCREW	LENGTH	PART
1 Phil / 2 Phil	2-4 and 5-10	3	A 83106
3/16 Slot / 5/16 Slot	6-8 and 10-12	3	A 83107
1 Square / 2 Square	6 and 8-10	3	A 83108

DOUBLE ENDED INSERT BITS PHILLIPS/PHILLIPS - 1/4" HEX



SIZE	SCREW	LENGTH	PART
2 Phil / 2 Phil	8-10 and 8-10	1-3/4	c 83104
2 Phil / 2 Phil	5-10 and 5-10	2-1/2	c 83105

SOCKET DRIVE ADAPTERS

- ALL SHANK EXTENSIONS EQUIPPED WITH BALL OR DURABLE PIN LOCK TO KEEP SOCKET FIRMLY IN PLACE



SIZE	FITS SOCKETS	LENGTH	PART
1/4" Hex	1/4" Square Drive	2"	c 83067
1/4" Hex	3/8" Square Drive	2"	c 83068
7/16" Hex	1/2" Square Drive	3"	B 83069

PHILLIPS / ACR BITS

- ACR OR ANTI CAM-OUT RECESS IS A SPECIALLY RIBBED TIP TO GRIP THE SCREW HEAD TIGHTLY REDUCING THE PRESSURE REQUIRED AND SLIPPAGE WHEN DRIVING OR REMOVING SCREWS
- SPECIAL RIDGES HELP IN THE REMOVAL OF RUSTED, STRIPPED OR DAMAGED SCREW HEADS
- RIDGES ALSO HOLD THE SCREW ONTO THE BIT MAKING INSTALLATION EASIER AND LESS CHANCE OF DROPPING THE SCREW DURING REMOVAL



1" INSERT BITS 1-15/16" POWER BITS

SIZE	PART	SIZE	PART
6-8	i 83077	6-8	i 83087
8-10	i 83078	8-10	i 83088
12-14	i 83079	12-24	i 83089

CIC 200™ NUTSETTER AND BIT SETS

ECONOMY POWER DRIVE KITS



DESCRIPTION	PART
3-Pc Mag. Nutsetter Set (1-3/4" long) 1/4, 5/16 and 3/8	A 83034
3-Pc Mag. Nutsetter Set (2-9/16" long) 1/4, 5/16 and 3/8	A 83035
3-Pc Non Mag. Nutsetter Set (1-3/4" long) 1/4, 5/16 & 3/8	A 83036
3-Pc Non Mag. Nutsetter Set (2-9/16" long) 1/4, 5/16 & 3/8	A 83037
3-Pc Phillips Bit Set (1-15/16" long) - #1, #2 and #3	A 83038
3-Pc Phillips Bit Set (2-3/4" long) - #1, #2 and #3	A 83039
3-Pc Phillips Insert Bits (1" Long) - #1, #2 and #3	A 83040
1-Pc Magnetic Bit Holder (3" Long)	

CIC 200 DELUXE POWER DRIVE SET

CONTAINS SIX OF THE MOST POPULAR DRIVERS IN A CONVENIENT, HEAVY-DUTY STEEL CARRYING CASE.

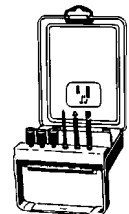

DESCRIPTION	PART
6 Piece Set - 1/4, 5/16 and 3/8 magnetic nutsetter, #1 and #2 phillips bit and 1/4 slotted bit	A 8825

TORX® SECURITY SCREWS

TAMPER-RESISTANT / STAINLESS STEEL

BUTTON HEAD MACHINE SCREWS

18-8 STAINLESS STEEL



- For general purposes. With a lower crown and shallower recess than round head screws.



17670

DIAMETER	LENGTH	PART NO.	DRIVER SIZE
4-40	1/4	R 43800	T-8
	3/8	R 43801	
	1/2	R 43802	
	3/4	R 43803	
	1	R 43804	
6-32	1/4	R 43805	T-10
	3/8	R 43806	
	1/2	R 43807	
	5/8	R 43808	
	3/4	R 43809	
	1	R 43810	
	1-1/2	R 43811	
8-32	1/4	R 43812	T-15
	5/16	R 43813	
	3/8	R 43814	
	1/2	R 43815	
	3/4	R 43816	
	1	N 43817	
	1-1/4	N 43818	
	1-1/2	N 43819	
	1-3/4	N 43820	
10-24	2	N 43821	T-25
	3/8	R 43822	
	1/2	R 43823	
	5/8	R 43824	
	3/4	R 43825	
	1	N 43826	
10-32	1-1/4	N 43827	T-25
	1-1/2	N 43828	
	3/16	R 43829	
	3/8	R 43830	
	1/2	R 43831	
	5/8	R 43832	
	3/4	R 43833	
1/4-20	1	N 43834	T-27
	1-1/4	N 43835	
	1-1/2	N 43836	
	1/4	N 43837	
	3/8	N 43838	
	1/2	N 43839	
	5/8	N 43840	
	3/4	N 43841	
	1	N 43842	
1-1/4	N 43843		
1-1/2	N 43844		
1-3/4	N 43845		
2	N 43846		
2-1/2	N 43847		

BUTTON HEAD SHEET METAL SCREWS

18-8 STAINLESS STEEL



- For general purposes. With a lower crown and shallower recess than round head screws.



17672

DIAMETER	LENGTH	PART NO.	DRIVER SIZE
#6	1/2	R 43850	T-10
	3/4	R 43851	
	1	N 43852	
	1-1/2	N 43853	
	2	N 43854	
#8	3/8	R 43855	T-15
	1/2	R 43856	
	3/4	R 43857	
	1	N 43858	
	1-1/3	N 43859	
	1-1/2	N 43860	
#10	1/2	R 43861	T-25
	5/8	R 43862	
	3/4	R 43863	
	1	N 43864	
	1-1/4	N 43865	
#12	1-1/2	N 43866	T-27
	1/2	R 43867	
	3/4	R 43868	
	1	N 43869	
	1-1/4	N 43870	
#14	1-1/2	N 43871	T-27
	1/2	N 43872	
	3/4	N 43873	
	1	N 43874	
	1-1/4	N 43875	
	1-1/2	N 43876	
	2	N 43877	

TORX® INSERT BITS

1/4" HEX



SIZE	SCREW SIZE	PART NO.
T8	#4	B 83099
T9	#5 - #6	B 83091
T10	#6 - #8	B 83092
T15	#8 - #10	B 83093
T20	#8	B 83094
T25	#10 - #12	B 83095
T27	#12 - 1/4	B 83096
T30	#14 - 1/4	B 83097
T40	5/16 - 3/8	B 83098

TORX® SECURITY SCREWS

TAMPER-RESISTANT / STAINLESS STEEL

FLAT HEAD MACHINE SCREWS

18-8 STAINLESS STEEL



- Installs flush with metal surfaces or countersinks with softer materials for clean appearance.



DIAMETER	LENGTH	PART NO.	DRIVER SIZE
6-32	1/4*	R 43880	T-10
	3/8	R 43881	
	1/2	R 43882	
	3/4	R 43883	
	1	N 43884	
	1-1/2	N 43885	
8-32	1/4*	R 43886	T-15
	3/8	R 43887	
	1/2	R 43888	
	5/8	R 43889	
	3/4	R 43890	
	1	N 43891	
	1-1/4	N 43892	
	1-1/2	N 43893	
10-24	3/8	R 43895	T-20
	1/2	R 43896	
	5/8	R 43897	
	3/4	R 43898	
	1	N 43899	
	1-1/4	N 43900	
10-32	3/8	R 43902	T-20
	1/2	R 43903	
	3/4	R 43904	
	1	N 43905	
	1-1/4	N 43906	
	1-1/2	N 43907	
12-24	1/2*	N 43908	T-25
	3/4	N 43909	
	1	N 43910	
1/4-20	3/8*	N 43911	T-27
	1/2*	N 43912	
	5/8	N 43913	
	3/4	N 43914	
	1	N 43915	
	1-1/4	N 43916	
	1-1/2	N 43917	
	1-3/4	N 43918	
	2	N 43919	
2-1/2	N 43920		

* Undercut

FLAT HEAD SHEET METAL SCREWS

18-8 STAINLESS STEEL

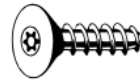

- Installs flush with metal surfaces or countersinks with softer materials for clean appearance.



DIAMETER	LENGTH	PART NO.	DRIVER SIZE
#6	1/2	R 43925	T-10
	5/8	R 43926	
	3/4	R 43927	
	1	R 43928	
	1-1/2	R 43929	
	#8	1/2	
5/8		R 43931	
3/4		R 43932	
1		R 43933	
1-1/4		N 43934	
1-1/2		N 43935	
2		N 43936	
#10	1/2	R 43937	T-20
	3/4	R 43938	
	1	N 43939	
	1-1/4	N 43940	
	1-1/2	N 43941	
#14	5/8	N 43942	T-30
	3/4	N 43943	
	1	N 43944	
	1-1/4	N 43945	
	1-1/2	N 43946	

PAN HEAD SELF DRILLING SHEET METAL SCREWS

410 STAINLESS STEEL



- Low profile large diameter head with a high-edged crown for increased strength.



DIAMETER	LENGTH	PART NO.	DRIVER SIZE
8-18	1/2	N 43950	T-20
	3/4	N 43951	
	1	N 43952	
	1-1/4	N 43953	
10-16	1/2	N 43954	T-25
	3/4	N 43955	
	1	I 43956	
	1-1/4	I 43957	
	1-1/2	I 43958	

CIC 200™ HEX-LOCK™ SECURITY SCREWS

TAMPER-RESISTANT STAINLESS STEEL

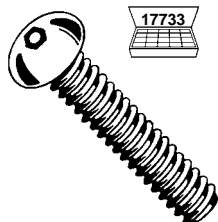

- 18-8 stainless steel – for corrosion resistance and durability
- Prevents pilferage, vandalism and unauthorized access
- Unique hex key/pin lock design – makes removal virtually impossible without specially machined keys
- Use for computers, videos, typewriters and office equipment; alarm systems, smoke detectors and lighting; bathroom fixtures and faucets; auditorium seats; benches; traffic lights; industrial safety guards; exhibits and displays; window and door locks; switch plates; hotel radios, clocks and televisions; thermostats and hundreds more

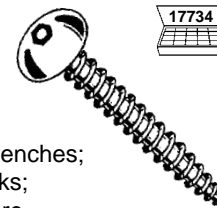

16

MACHINE SCREWS						SHEET METAL SCREWS		
LENGTH	6-32	8-32	10-24	10-32	1/4-20	NO. 6	NO. 8	NO. 10
1/4	—	—	—	—	—	—	—	—
3/8	R 44101	—	—	—	—	R 44000	R 44006	—
1/2	R 44102	R 44110	R 44119	R 44127	—	R 44001	R 44007	R 44014
5/8	—	—	—	—	—	—	—	—
3/4	R 44104	R 44112	R 44121	R 44129	R 44137	R 44003	R 44009	R 44016
1	—	R 44113	R 44122	R 44130	R 44138	R 44004	R 44010	R 44017
1-1/4	R 44106	—	—	—	—	—	R 44011	R 44018
1-1/2	—	R 44115	—	—	R 44140	—	R 44012	R 44019
2	—	—	—	—	—	—	—	R 44020

CIC 200™ HEX-LOCK SECURITY DRIVERS AND NUTS

Hex-LOCK drivers are the only tools for installing or removing Hex-LOCK security screws. Break-away nuts have a pre-designed break-away torque that leaves a tamper-resistant nut on machine screws.

HEX-LOCK DRIVER BITS



1/4" HEX DRIVE

SIZE	SCREW	PART
3/32	4-40	B 44203
1/8	6-32	D 44204
5/32	8-32 to 1/4-20	D 44206
3/16	5/16	B 44207
7/32	3/8	B 44208

HEX-LOCK KEYS



SIZE	SCREW	PART
1/8	6-32	D 44200
5/32	8-32 to 1/4-20	D 44202

BREAK-AWAY NUTS

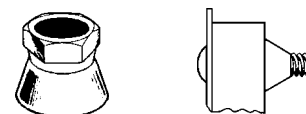

SIZE	BREAK-OFF TORQUE	PART
10-24	25-35 in. lbs.	R 44190
1/4-20	60-80 in. lbs.	R 44194

CIC 200™ THREAD CUTTING SCREWS

ELIMINATES EXPENSIVE TAPPING COSTS

Specially designed to thread their own hole through strong, sharp threads with a minimum amount of torque. The type F point provides cleaner threads and positive chip ejection.

SLOTTED HEX WASHER HEAD WITH TYPE F POINT

SLOTTED, INDENTED HEX WASHER HEAD PROVIDES FOR INSTALLATION VERSATILITY

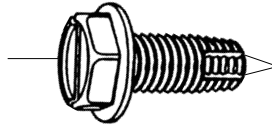

THREAD CUTTING SLOTS PROVIDE POSITIVE CHIP EJECTION

FEATURES:

- Eliminates expensive tapping costs
- One side installation with no need for nuts
- Special hardening process provides maximum resistance to breakage
- Washer head provides an even load bearing surface



LENGTH	6-32	8-32	10-24	10-32	12-24	1/4-20	5/16-18	3/8-16
1/4	T 7033	T 7038	–	–	–	–	–	–
3/8	T 7034	T 7039	T 7004	T 7046	–	–	–	–
1/2	T 7035	T 7040	T 7005	T 7007	–	T 7009	–	–
3/4	T 7036	T 7041	T 7006	T 7008	T 7054	T 7011	R 7020	N 7026
1	T 7037	T 7000	T 7042	T 7047	T 7055	T 7012	R 7021	N 7027
1-1/4	–	T 7001	T 7043	T 7048	–	T 7010	N 7017	N 7028
1-1/2	–	T 7002	T 7044	T 7049	–	T 7013	N 7018	N 7029
2	–	T 7003	T 7045	T 7053	–	R 7014	N 7019	I 7030
2-1/2	–	–	–	–	–	R 7015	N 7024	I 7031
3	–	–	–	–	–	R 7016	N 7025	I 7032

RECOMMENDED DRILL SIZES FOR THREAD CUTTING SCREWS (60%)

SCREW	DRILL	DRILL PART	SCREW	DRILL	DRILL PART
6-32	34	10034	12-24	16	10016
8-32	29	10029	1/4-20	5	10005
10-24	23	10023	5/16-18	G	10207
10-32	20	10020	3/8-16	O	10215

TAMPERPROOF SCREWS

TRUSS HEAD BARREL NUTS AND SHOULDER SCREWS

BARREL NUTS



SIZE	THREAD	PART
1/4 x 1/2	10-24	T 10634
1/4 x 5/8	10-24	T 10636

SHOULDER SCREWS

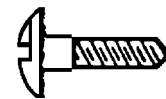

SIZE	THREAD	PART
1/4 x 15/16	10-24	T 10650
1/4 x 1-1/16	10-24	T 10652
1/4 x 1-3/16	10-24	T 10654
1/4 x 1-5/16	10-24	T 10656

TAMPERPROOF UN-DO-IT MANUAL DRIVER

SIZE	SCREW	PART
#1	6-8	A 20101
#2	8-10	A 20105
#3	10-14	A 20110

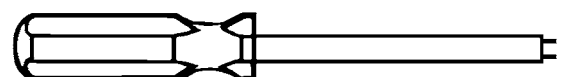

CIC 200™ THUMB SCREWS

THUMB SCREW KNOBS

Instantly produce any size/style thumb screw. Make thousands of different screw, knob and color combinations.

- ACETAL RESIN CONSTRUCTION FOR STRENGTH AND DURABILITY
- COLOR-CODED FOR EASY IDENTIFICATION
- FOUR STYLES ACCOMMODATE DIFFERENT LEVERAGE/SPEED REQUIREMENTS

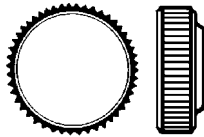

KNURLED KNOB

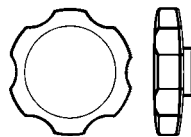

ROSETTE KNOB

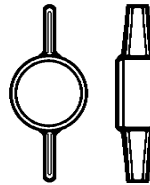

TEE KNOB

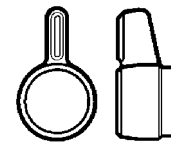

"L" KNOB

EASY AS 1, 2, 3!

1. SELECT A THUMB SCREW KNOB.
2. SELECT A CIC 150 OR CIC 200 SOCKET HEAD CAP SCREW (SEE CATALOG SECTION 12).
3. PRESS TOGETHER IN VISE, PRESS OR WITH PLIERS.

KNURLED KNOB

SOCKET HEAD CAP SCREW SIZE	COLOR	DIAMETER	THICKNESS		PART
#4	Black	5/16	11/64	R	44040
#4	Red	5/16	11/64	R	44041
#6	Black	3/8	3/16	R	44044
#6	Red	3/8	3/16	R	44045
#8	Black	1/2	7/32	R	44048
#8	Red	1/2	7/32	R	44049
#10	Black	5/8	1/4	R	44052
#10	Red	5/8	1/4	R	44053
1/4	Black	3/4	5/16	R	44056
1/4	Red	3/4	5/16	R	44057
1/4	Black	1	5/16	N	44060
1/4	Red	1	5/16	N	44061

ROSETTE KNOB

1/4	Black	1-1/2	15/32	L	44064
1/4	Red	1-1/2	15/32	L	44065
5/16	Black	1-1/2	13/32	L	44068
5/16	Red	1-1/2	13/32	L	44069
3/8	Black	1-1/2	15/32	L	44072
3/8	Red	1-1/2	15/32	L	44073

TEE KNOB

#10	Black	1	1/4	R	44076
#10	Red	1	1/4	R	44077
1/4	Black	1-1/4	5/16	R	44080
1/4	Red	1-1/4	5/16	R	44081
5/16	Black	1-1/2	13/32	R	44084
5/16	Red	1-1/2	13/32	R	44085
3/8	Black	1-3/4	15/32	R	44088
3/8	Red	1-3/4	15/32	N	44089





"L" KNOB

#10	Black	9/16	11/32	R	44092
#10	Red	9/16	11/32	R	44093
1/4	Black	11/16	7/16	R	44096
1/4	Red	11/16	7/16	R	44097

CIC 200™ BI-CUT SCREWS

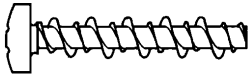
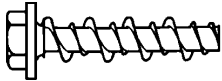
PHILLIPS BINDING AND HEX WASHER HEAD

High performance double-thread design for plastic, fiberglass, wood, masonite and other low density materials. Lower driving torque, greater pull-out strength and maximum protection against stripping, cracking and splitting. High 30° and low 60° included angle threads.

BINDING HEAD					HEX WASHER HEAD					SUGG. DRILL SIZE		
												
												
LENGTH	NO. 4	NO. 6	NO. 8	NO. 10	NO. 4	NO. 6	NO. 8	NO. 10	SCREW	DRILL	PART	
1/4	T 95000	T 95006	-	-	T 95100	T 95106	-	-	No. 4	5/64	91005	
3/8	T 95002	T 95008	T 95012	-	T 95102	T 95108	T 95112	-	No. 6	3/32	91006	
1/2	T 95004	T 95010	T 95014	T 95018	T 95104	T 95110	T 95114	T 95118	No. 8	1/8	91008	
5/8	-	-	-	T 95020	-	-	-	T 95120	No. 10	9/64	91009	
3/4	-	-	T 95016	T 95022	-	-	T 95116	T 95122	-	-	-	

DRYWALL SCREWS

HEAVY FRAME - DRILL POINT

- ATTACHES DRYWALL, INSULATION BOARD, WOOD, ETC. TO 14-20 GAUGE METAL STUDS
- UNIQUE HEAD DESIGN MINIMIZES PAPER BURRS
- NO. 2 PHILLIPS DRIVE
- ZINC PLATED

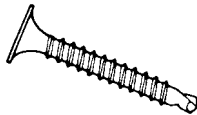

SIZE	PART	SIZE	PART
6 x 1	T 13036	8 x 2-3/8	T 13042
6 x 1-1/4	T 13038	8 x 2-5/8	T 13044
6 x 1-5/8	T 13040	8 x 3	T 13046
7 x 1-7/8	T 13041	-	-

LIGHT FRAME - "S" POINT

- ATTACHES DRYWALL TO 20-25 GAUGE STEEL
- UNIQUE HEAD DESIGN MINIMIZES PAPER BURRS
- NO. 2 PHILLIPS DRIVE
- ZINC PLATED

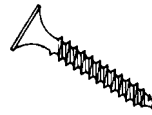

SIZE	PART	SIZE	PART
6 x 1	T 13043	8 x 2-1/2	T 13020
6 x 1-1/8	T 13045	8 x 3	T 13022
6 x 1-1/4	T 13047	10 x 3-1/2	T 13026
7 x 2	T 13053	10 x 4	T 13028
7 x 2-1/4	T 13056	-	-

DRYWALL SCREW SETTER

- SETS DRYWALL SCREW INTO DRYWALL
- EASY TO USE IN DRILLS OR SCREW GUNS



DESCRIPTION	PART
Drywall Screw Setter	C 83065

COARSE THREAD - YELLOW ZINC



- ATTACHES DRYWALL TO WOOD
- SUPERIOR HOLDING POWER
- EASY PENETRATION
- UNIQUE HEAD DESIGN MINIMIZES PAPER BURRS
- NO. 2 PHILLIPS DRIVE
- YELLOW ZINC PLATED FOR EASY IDENTIFICATION AND DURABILITY

SIZE	PART	SIZE	PART
6 x 1	T 13010	7 x 2-1/4	T 13015
6 x 1-1/8	T 13011	8 x 2-1/2	T 13016
6 x 1-1/4	T 13012	8 x 3	T 13017
6 x 1-5/8	T 13013	10 x 3-1/2	T 13018
7 x 2	T 13014	10 x 4	T 13019

COARSE THREAD - BLACK

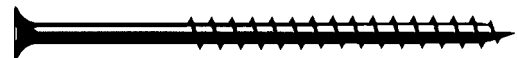

- ATTACHES DRYWALL TO WOOD
- SUPERIOR HOLDING POWER
- EASY PENETRATION
- UNIQUE HEAD DESIGN MINIMIZES PAPER BURRS
- NO. 2 PHILLIPS DRIVE
- BLACK PHOSPHATE FINISH

SIZE	PART	SIZE	PART
6 x 1	X 13000	7 x 2-1/4	W 13005
6 x 1-1/8	X 13001	8 x 2-1/2	V 13006
6 x 1-1/4	X 13002	8 x 3	V 13007
6 x 1-5/8	X 13003	10 x 3-1/2	T 13008
7 x 2	W 13004	10 x 4	T 13009

TRIM SCREWS

IDEAL FOR TRIM AND FINISH WORK

PHILLIPS DRIVE

- ATTACHES WOOD TRIM OVER SINGLE OR DOUBLE LAYER GYPSUM BOARD TO 20-25 GAUGE STEEL
- SUPERIOR HOLDING POWER
- EASY PENETRATION
- UNIQUE HEAD DESIGN MINIMIZES THE NEED TO FILL HOLES
- NO. 2 PHILLIPS DRIVE
- BLACK PHOSPHATE FINISH



SIZE		PART
6 x 1-5/8	T	13090
6 x 2-1/4	T	13091

SQUARE DRIVE

- ATTACHES WOOD TRIM OVER SINGLE OR DOUBLE LAYER GYPSUM BOARD TO 20-25 GAUGE STEEL
- SUPERIOR HOLDING POWER
- EASY PENETRATION
- UNIQUE HEAD DESIGN MINIMIZES THE NEED TO FILL HOLES
- SQUARE DRIVE
- BLACK PHOSPHATE FINISH



SIZE		PART	SIZE		PART
6 x 1	T	13092	6 x 2-1/4	T	13094
6 x 1-5/8	T	13093	8 x 3	T	13095

CIC 200™ SEX BOLTS

SMOOTH TRUSS HEADS - NO DRIVE

The knurled barrel keeps the sex bolt from spinning while the flat head screw is tightened from the other side. These parts are secure as there is no way to turn the sex bolt without a drive in the head. Mating screw is phillips flat head, steel and plated to match the finish on the barrel.

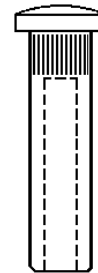
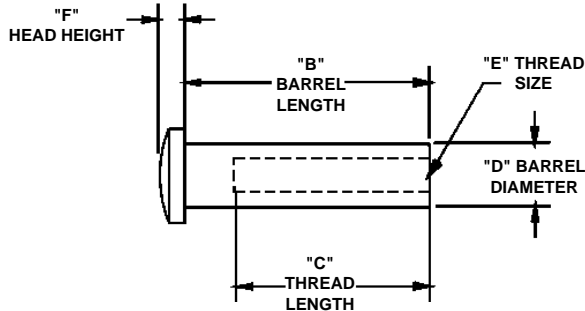

PHILLIPS FLAT HEAD MACHINE SCREW INCLUDED

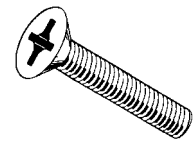

BRASS MATERIAL

D BARREL DIAMETER	B BARREL LENGTH	C THREAD DEPTH	A HEAD DIAMETER	F HEAD HEIGHT	E THREAD SIZE	PLATING	PHIL FLAT HD MACHINE SCREW	PART
5/16"	1-3/16	3/4	1/2	1/8	10-32	Chrome	10-32 x 1	E 10660
5/16"	1-3/16	3/4	1/2	1/8	10-32	Clear	10-32 x 1	E 10661
5/16"	1-9/16	3/4	1/2	1/8	10-32	Chrome	10-32 x 1	E 10663
5/16"	1-9/16	3/4	1/2	1/8	10-32	Clear	10-32 x 1	E 10664
3/8"	1-9/16	1-1/4	9/16	5/32	1/4-20	Chrome	1/4-20 x 1-1/2	E 10666
3/8"	1-9/16	1-1/4	9/16	5/32	1/4-20	Clear	1/4-20 x 1-1/2	E 10667

STAINLESS STEEL MATERIAL

5/16"	1-3/16	3/4	1/2	1/8	10-32	None	10-32 x 1	E 10662
5/16"	1-9/16	3/4	1/2	1/8	10-32	None	10-32 x 1	E 10665
3/8"	1-9/16	3/4	9/16	5/32	1/4-20	None	1/4-20 x 1	B 10669
3/8"	2-1/16	3/4	9/16	5/32	1/4-20	None	1/4-20 x 1	B 10670

ONE-WAY SCREW REMOVER / INSTALLER

MAKES INSTALLATION OF ONE-WAY SCREWS FAST AND EASY

- PATENTED ONE WAY SCREW REMOVER AND INSTALLER
- MAKES INSTALLATION OF ONE-WAY SCREWS FAST AND EASY
- ALLEN SET SCREW FOR ADJUSTMENT OF BIT DEPTH (HEX KEY INCLUDED)
- USE WITH CORDED OR CORDLESS SCREWGUNS AND DRILLS



DESCRIPTION	FOR SCREW HEAD DIAMETER	PART	
#6 One Way Screw Remover / Installer	.225"	A	81325
#8 One Way Screw Remover / Installer	.260"	A	81326
#10 One Way Screw Remover / Installer	.339"	A	81327
#12 One Way Screw Remover / Installer	.392"	A	81328
#14 One Way Screw Remover / Installer	.443"	A	81329

SCREW GUIDES

MAGNET HOLDS AND GUIDES SCREWS IN THE CORRECT POSITION



Compact Screw Guide



Standard Screw Guide

- HIGH STRENGTH NEODYMIUM MAGNET
- HOLDS AND GUIDES SCREWS IN THE CORRECT POSITION WITHOUT WOBBLING OR DISENGAGING FROM THE BIT
- BODY OF SCREW GUIDE SPINS FREELY FOR IMPROVED STABILITY



1. Place correct size driver bit into Screw Guide. Then place screw on bit (the guide is magnetic and holds screw on driver bit).



2. Slide Screw Guide over screw to hold screw in place while driving.

SIZE	OVERALL LENGTH	PART	
Compact	3-1/16"	C	83028
Standard	4-5/16"	A	83029

FLEX-A-BIT® FLEXIBLE EXTENSIONS

FLEX-A-BIT®

- THE ONLY FLEXIBLE EXTENSION WHERE THE ENTIRE OUTER SURFACE DOES NOT ROTATE
- FLEXES TO 90°
- USE IN HARD TO REACH PLACES – IN CARS, KITCHEN CABINETS, FURNITURE, APPLIANCES, ETC.
- LIGHT DUTY IS RATED FOR 3.5 FOOT POUNDS OF TORQUE
- INDUSTRIAL DUTY IS RATED FOR 13 FOOT POUNDS OF TORQUE
- FLEX-A-BIT® PLUS IS DESIGNED FOR USE IN ELECTRIC OR HEAVY DUTY RECHARGEABLE DRILLS

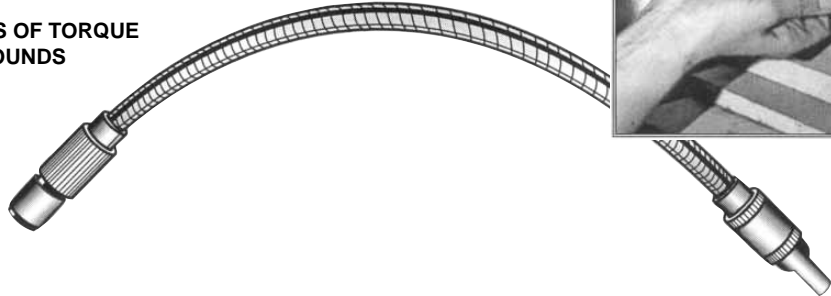
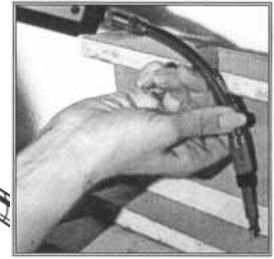

16

DESCRIPTION	PART	
Flex-a-Bit® 7-1/2", Light Duty 1/4" Hex	A	83130
Flex-a-Bit® Plus 11", Industrial Duty, 1/4" Hex	A	83131

SCREWDRIVERS

SECURITY SELECT-A-BIT 16-IN-1 MULTI-DRIVER

- 16 BITS IN THE HANDLE AND A 1/4" NUT DRIVER IN THE NOSEPIECE FOR MAXIMUM VERSATILITY
- EXTRA-LONG (3") DOUBLE ENDED BITS ARE MADE OF HARDENED S2 STEEL AND ARE UNIVERSALLY SIZED FOR SUPERIOR STRENGTH
- PATENTED END-CAP ALLOWS INDIVIDUAL BIT REMOVAL, YET WON'T TURN DURING USE
- INDUSTRIAL-QUALITY DRIVERS FOR LONG LIFE



SCREWDRIVER INCLUDES THESE SECURITY BITS:

- SPANNER 4, 6, 8 AND 10
- TORX® SECURITY 10, 15, 20 AND 25
- HEX SECURITY 1/8", 9/64", 5/32" AND 3/16"
- ROBERTS/SQUARE SECURITY 1 AND 2
- PHILLIPS 2 AND SLOTTED 7/32"

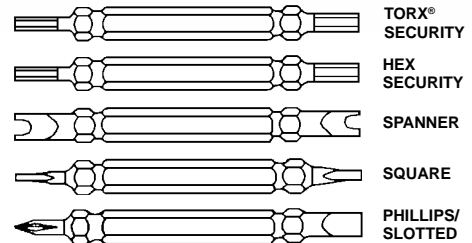

DESCRIPTION	PART	DESCRIPTION	PART
Screwdriver	A 8025	Replacement Spanner 4-6 Bit	A 83114
Replacement Torx T10-T15 Bit	A 83110	Replacement Spanner 8-10 Bit	A 83115
Replacement Torx T20-T25 Bit	A 83111	Replacement Square 1-2 Bit	A 83116
Replacement Hex 3/16-5/32 Bit	A 83112	Replacement Phillips/Slotted Bit	A 83117
Replacement Hex 1/8-9/64 Bit	A 83113		

SCREWDRIVERS

10-IN-1 SCREWDRIVER

- INCLUDES:
 - 2 PHILLIPS BITS
 - 2 SLOTTED BITS
 - 2 TORX® BITS
 - 2 SQUARE BITS
- SHAFT AND BIT HOLDER DOUBLE AS HEX DRIVERS
- BITS STORE CONVENIENTLY IN THE SHAFT WHEN NOT IN USE
- HIGH-IMPACT PLASTIC HANDLE
- 7.5" L X 1.0" W

The 10-in-1 Screwdriver includes these bits:

- Phillips: #1 and #2
- Slotted: 3/16" and 1/4"
- TORX®: T15 and T20
- Roberts/Square: #1 and #2
- HEX: 1/4" and 5/16"



16

DESCRIPTION	PART	
10-in-1 Screwdriver	A	8020
#1 Phillips x 3/16" Slotted Bit - Replacement	A	83125
#2 Phillips x 1/4" Slotted Bit - Replacement	A	83126
#1 x #2 Square Recessed Bit - Replacement	A	83127
T15 x T20 TORX® Bit - Replacement	A	83128

8-IN-1 MULTI-TOOL STUBBY SCREWDRIVER

- Ideal for hard-to-reach areas
- Professional-grade tool includes seven (7) of the most common sized screwdriving bits
- All bits are conveniently and securely stored inside the tool
- The shank functions as a 1/4" nut driver
- Shank is magnetic, so bits are held securely in place
- Non-slip protouch™ grip, provides maximum torque, with incredible comfort and control



DESCRIPTION	PART	
8-in-1 Multi-Tool Stubby Screwdriver	A	8028

SCREWDRIVERS

DIAL-N-LOAD AUTO SCREWDRIVER

- All high grade metal component construction
- Chemical and shock resistant plastics
- Comfortable, attractive, anti-roll handle
- Rotating front collar for fine adjustment
- Comes loaded with 6 commonly used industrial grade bits
 - Phillips: PH1, PH2, PH3; Slotted: 1/8", 3/16", 1/4"
- No contact bit changes
- Bit loads can be fully customized (1" length bits only)
- Bit tips are magnetic

16

Exclusive pump action mechanism changes bits within seconds

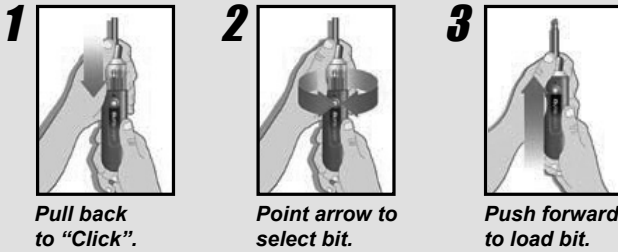

31 Piece Bit Set - P/N 83129



Includes the following:

- Phillips: P0, P1, PHR2, P3
- Slotted: 5/32" (2 pieces), 7/32", 1/4", 9/32"
- TORX®: T10, T15, T20, T25, T27, T30, T40
- Square: 1, 2, 3
- Hex: 5/64", 3/32", 7/54", 1/8", 9/64", 5/32", 3/16", 7/32", 1/4"
- Quick change locking bit adapter (*bonus piece)

* Not specifically intended as an extension to Dial-N-Load Auto Screwdriver... gives you flexibility to move back and forth with these bits in your driver and power tool.



P/N 8023

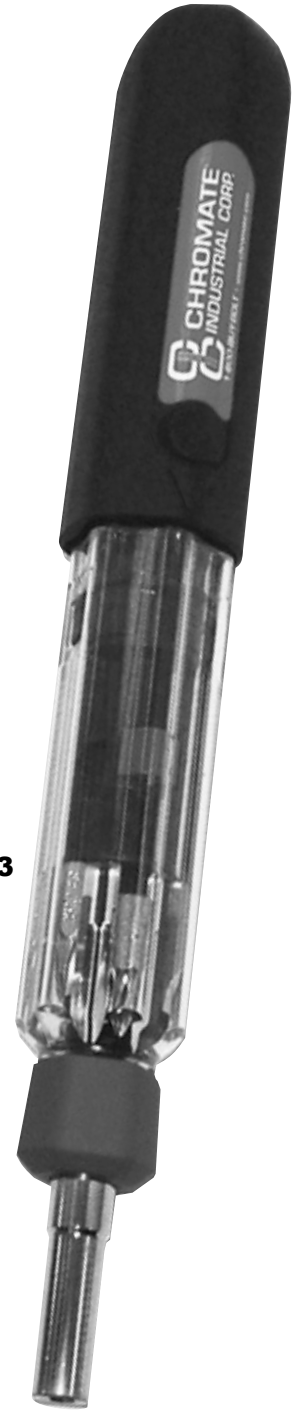

DESCRIPTION	PART
Dial-N-Load Auto Screwdriver	A 8023
31 Piece Bit Set	A 83129

SCREWDRIVERS

COMPACT 7 PIECE SCREWDRIVER SET WITH BELT POUCH

Includes

- 3 Phillips bits (P/Ns 83172–83174)
- 3 Slotted bits (P/Ns 83175–83177)
- 1/4" Universal bit holder (P/N 83171)
- Handle with integrated bit storage
- Belt pouch

Application

- Suitable for 1/4" DIN 3126-C 6.3 and E 6.3 (ISO 1173) hexagon socket insert bits

Features

- The miracle tool for manual and power tool applications
- Includes bits that can be stored in the handle
- 1/4" universal bit holder can be used as a power tool adaptor
- Quick release chuck
- Supplied in a rugged belt pouch

Benefits

- Screwdriver tip made from powerbit grade steel for unbeatable strength
- Handle uniquely fits the contour of hands during use
- Handle has non-roll feature

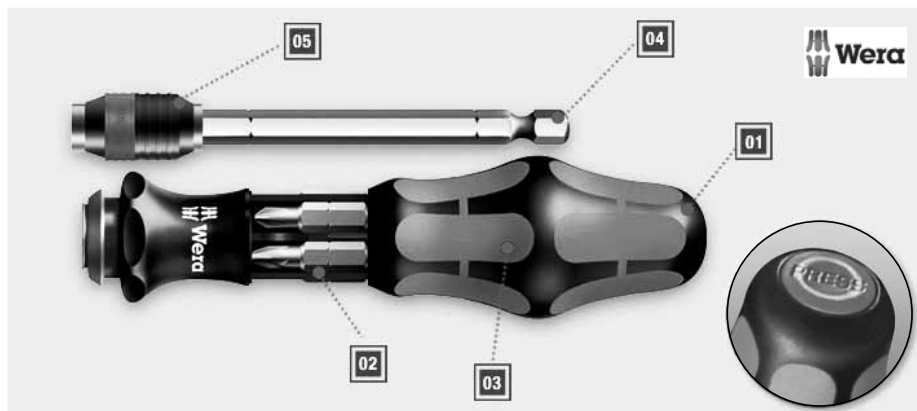

- 01** Spring-loaded opening mechanism allows access to bit storage
- 02** 6-bit magazine integrated in the handle
- 03** Ergonomic, non-roll handle
- 04** 1/4" universal bit holder that can be used as a power tool adaptor
- 05** Quick release chuck



P/N 83170

DESCRIPTION	PART
7 Piece Screwdriver Set	A 83170
1/4" Universal Bit Holder	A 83171
Phillips Bit - #1	A 83172
Phillips Bit - #2	A 83173
Phillips Bit - #3	A 83174
Slotted Bit - 0.6 x 4.5 x 25mm	A 83175
Slotted Bit - 1.0 x 5.5 x 25mm	A 83176
Slotted Bit - 1.2 x 6.5 x 25mm	A 83177

SCREWDRIVERS - INSULATED

1000V INSULATED SCREWDRIVER SET

• 18 Piece Set includes:

- Slotted
 - Phillips
 - Pozidriv
 - PlusMinus/MCB
 - Switchboard Cabinet Blades
- Individually tested for dielectric strength under a 10,000V load, to guarantee safe working at 1,000V (1000V AC and 1500V DC)
 - Drop tested at extreme temperatures to ensure insulation won't fail
 - Screwdriver tip made from powerbit grade steel for unbeatable strength
 - VDE handle with blade auto-lok system
 - Handle uniquely fits the hands contours during use
 - Supplied in a rugged belt pouch
 - Individual bits also sold separately



Set contents:

- 817 VDE Handle
- 1 Voltage Tester
- 4 Slotted Bits - 2.5, 3.5, 4 and 5.5mm
- 2 Phillips Bits - PH1 and PH2
- 2 Phillips Bits - PHS1 and PHS2 minus blades for combination screws
- 2 Pozidriv Bits - PZ1 and PZ2
- 2 Pozidriv Bits - PZS1 and PZS2 minus blades for combination screws
- 4 Switchboard Cabinet Blades - Square 6.3 and 8.1mm, triangular and round

DESCRIPTION	PART	
1000V Insulated Screwdriver Set	A	8029
817 VDE Handle	A	83150
Voltage Tester	A	83151
Slotted Bit - 2.5mm	A	83152
Slotted Bit - 3.5mm	A	83153
Slotted Bit - 4mm	A	83154
Slotted Bit - 5.5mm	A	83155
Phillips Bit - PH1	A	83156
Phillips Bit - PH2	A	83157
Phillips Bit - PHS1 minus blades for combination screws	A	83158
Phillips Bit - PHS2 minus blades for combination screws	A	83159
Pozidriv Bit - PZ1	A	83160
Pozidriv Bit - PZ2	A	83161
Pozidriv Bit - PZS1 minus blades for combination screws	A	83162
Pozidriv Bit - PZS2 minus blades for combination screws	A	83163
Switchboard Cabinet Blade - Square 6.3mm	A	83164
Switchboard Cabinet Blade - Square 8.1mm	A	83165
Switchboard Cabinet Blade - Triangular 8mm	A	83166
Switchboard Cabinet Blade - SI-Round 14mm	A	83167